

Introduction of Safety Control of AC Servo Press

Yukio Hata

Hitoshi Sakurai

Hisanori Takeuchi

Yoshinori Matsushita

Komatsu Industries Corp. came up with a direct-acting AC servo press for the first time in 1998. Since then, the company has continually installed an AC servo in its mechanical presses. Recently, it introduced to the market the progressive AC servo presses H2F and H4F (input of material to and output of finished product from the press are done automatically). Last year, we developed and put on the market the hand-in-die type H1F press (input of material to and output of finished product from the press are done by the operator) whose safety control is said to be the most difficult among mechanical presses.

This paper describes the safety control system that is incorporated in the hand-in-die type AC servo press H1F.

Key Words: Press, Hand-In Dies, Servo, Safety Control, Redundancy Design, SIT, Risk Assessment.

1. Introduction

Amid the ongoing domestic deindustrialization, AC servo presses are becoming widespread as a means of reforming press working and materials and allowing for plastic working almost comparable in precision to machining. Characteristically, the AC servo press employs an AC servomotor, in place of the conventional clutch brake, to improve the slide bottom dead center accuracy (this was formerly difficult to control), permit stopping the slide in the middle of press work and setting a desired motion shape, and so on.

Since presses are machines which have caused many labor accidents in the past, various measures to improve the safety of presses have been taken. Nevertheless, labor accidents caused by presses in Japan are still much more frequent than in the other industrialized countries. Therefore, a higher degree of safety control of presses is called for. However, there are insufficient safety standards for AC servo presses in Japan. As a matter of fact, at present, only safety standards for the conventional presses with clutch brake have been established.

Recently we developed a servo press control system (SIT III) for safely controlling the manual press working with an AC servo press (H1F). This paper describes how our system conforms to various safety standards and secures the safety of H1F. (Fig. 1)

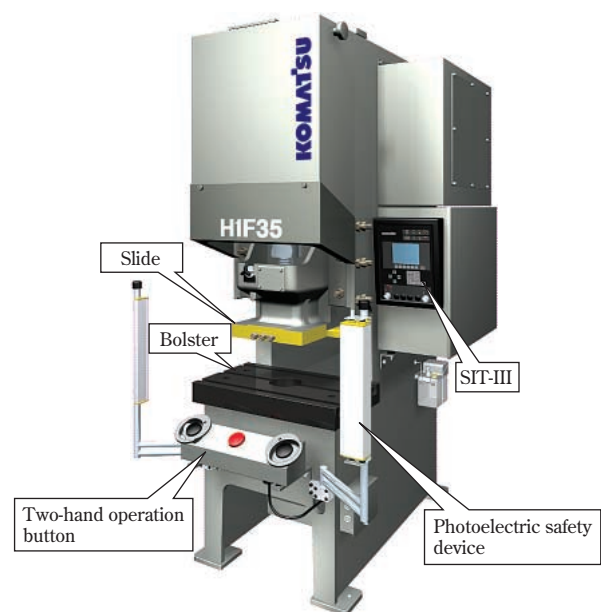

Fig. 1 AC servo press H1F

2. Hand-in die servo press H1F

(1) Safety standards for hand-in die servo presses

The hand-in die press is generally recognized as a very dangerous machine because the operator has to put a material into the slide and takes the finished product out by hand.

As the representative standards for securing the safety of hand-in die presses, there are the following safety standards for power mechanical presses.

- ① EN692/EN693 in Europe
- ② OSHA and ANSI B11.1 and B11.3 in the United States
- ③ Standards for Power Press Mechanical Structures and safety standards of JIS, etc. in Japan
- ④ General international standards for securing of safety (ISO 12100, ISO 13849-1)

On the basis of the above standards, the governments of the individual countries demand high degrees of safety by national laws and national standards.

In addition, there is the WTO/TBT Agreement, an international convention, aimed to promote the economic globalization, prevent the trade friction caused by unduly stringent application or abuse of the regulation for verification of foreign standards of industrial products, including presses, and unify the industrial standards, safety and environmental regulations, etc. of individual countries. Japan is a signatory to the agreement.

In line with the above agreement, the governments of the individual countries are, as a rule, adjusting their national standards (e.g., JIS) to the appropriate international standards, such as the ISO (International Standards Organization) and the IEC (International Electrotechnical Commission Standards).

As a recent domestic movement relating to the safety of machines, the Ministry of Health, Labor and Welfare published in June 2001 the “Guidelines on General Safety Criteria of Machines” in accordance with ISO 12100, an international A-standard (basic safety standards), to provide manufacturers with guidance in the implementation of risk assessment and safety measures.

Since it is necessary to implement safety measures paying attention to industrial internationalization in the future, Komatsu has carried on research and development on the control and safety of AC servo presses since last year.

(2) Mechanical structure of AC servo press H1F and concept of securing of safety

The mechanical structure of H1F is shown in Fig. 2.

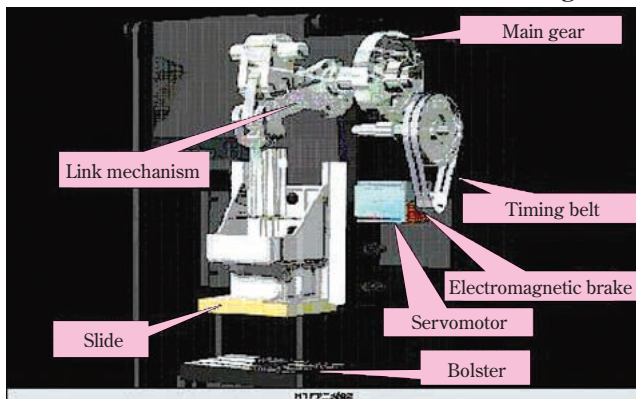

Fig. 2 Mechanical structure of H1F

A press is a machine in which a cope is set on the slide and a drag is set on the bolster, a material to be worked on is placed on the drag, and then the slide is moved up and down to press the material into a desired shape.

The conventional press employs a main motor to turn a flywheel and store rotational energy for driving the main gear – the key component of its driving system. The energy stored is transmitted to the main gear via a clutch brake and used to move the slide up and down and press the material (Fig. 3: Driving mechanism of press).

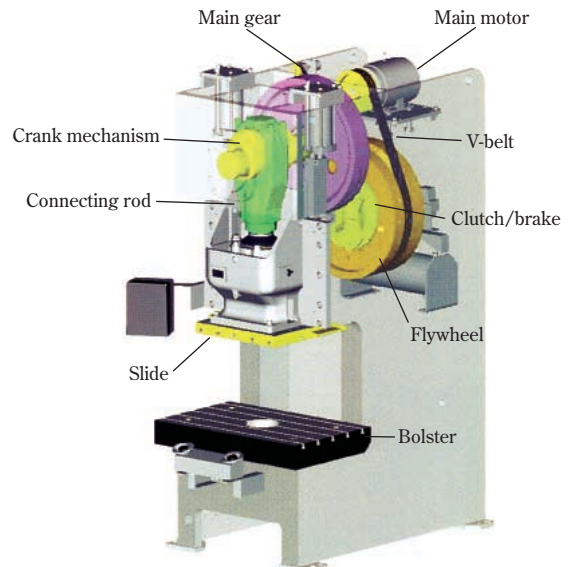

Fig. 3 Press driving mechanism

Therefore, to secure the safety of conventional presses, the utmost attention has been paid to securing the safety of on/off operation of the clutch brake which transmits the flywheel energy to the main gear.

AC servo press H1F resembles a conventional link press in that the slide is driven up and down by the main gear via a link mechanism. The difference is that the energy for rotating the main gear is directly transmitted to the main gear from a servomotor via a timing belt. Therefore, if the servomotor overruns, it directly leads to an overrun of the slide vertical motion, which in turn can cause a serious accident. Since the AC servo press does not have a clutch brake which cuts off the rotational energy, it is necessary that the mechanism provided for cutting off the servomotor energy (source of driving force) should have safety and reliability equal or superior to those of the clutch brake of a conventional press.

Concerning the securing of safety using a servomotor control system available on the market which can hardly demonstrate the safety of AC servo press control using SIT III, we shall describe below the content of control implemented to secure safety equal or superior to that of a conventional press.

3. Risk assessment and safety requirements of press action control

(1) Risk assessment of AC servo press action control

In line with the “Guidelines on General Safety Criteria of Machines,” every control system needs to be evaluated according to the principles of risk assessment described in JIS B 9702 (ISO 14121), and safety measures shall be determined based on the appropriate category of JIS B 9705-1 (ISO 13849-1).

Excerpts of a risk assessment carried out on the AC servo press control system are given below. (Table 1, Table 2)

(2) Safety requirements of AC servo press action control

The safety requirements of AC servo press safety control based on the results of the risk assessment of the AC servo press control system carried out according to JIS B 9702

(Appendix A) are divided roughly into the following five items.

- ① Redundancy design of means of sensing slide position and constant monitoring mechanism
- ② Duplication and monitoring of control circuit system
- ③ Duplication and monitoring of starter circuit
- ④ Redundancy design of overrun detection and circuit breaking
- ⑤ Redundancy design of control program
- [⑥ Installation of safety device]

The above control mechanisms of the AC servo press are required to meet Category 3 or 4 of JIS B 9705-1.

We shall describe below the contents of the safety measures we implemented with SIT III for safety control the AC servo press using a general-purpose AC servomotor.

Table 1 Risk assessment based on JIS B 9702: Appendix A (Controllers)

Identification of risk source			Risk assessment					Appropriate safety measure (Items ① through ⑥ are types of methods for securing safety.)
No.	Risk	Risk zone	Possibility of being exposed to risk	Seriousness of damage C	Frequency of being exposed to risk F	Possibility of avoiding risk P	Category of safety measure	
15 [Unexpected start, overrun/over-speed, or similar disorder]								
15.1	Failure / disorder of control system	Overrun caused by failure of position sensor	Yes	C2	F2	P1	4	① Redundancy design using different types of sensors and providing of constant monitoring mechanism
		Sudden start caused by short-circuit/failure of starter circuit	Yes	C2	F1	P1	3	② Duplication and monitoring of circuit system ③ Duplication and monitoring of starter circuit
		Overrun caused by failure of servo system	Yes	C2	F1	P1	3	④ Redundant overrun detection/circuit breaking mechanisms
15.2	Restoration of energy supply after interruption	Sudden start of action	Yes	C1	F2	P1	3	⑥ Installation of photoelectric safety device ③ Providing of restarting circuit
15.5	Software error	Sudden start of action	Yes	C2	F1	P1	3	⑤ Control system: Safety category 3 or higher (prevention of software errors by providing separate CPU/separate software)
16 Failure to stop machine in optimum condition								
16		Double stopping due to overrun	Yes	C2	F1	P1	3	④ Redundant stop control circuit ④ Speed recognition/safety confirmation system (safety category 3 or higher)
17 Rotational speed fluctuation								
17		Sudden start of action	Yes	C1	F1	P2	1	④ Speed recognition/safety confirmation system (safety category 3 or higher)
19 Failure of control circuit								
19		Failure of safety device circuit	Yes	C2	F1	P1	3	② Duplication and monitoring of circuit system
		Failure of output	Yes	C2	F1	P1	3	

Table 2 Classification of safety of control functions (JIS B 9705-1)

Category of safety measure	Method for securing safety of control function
B	All components only function as non-safety parts.
1	Components which have proven reliability are employed for safety-related parts.
2	Functions for securing safety (safety-related parts) are checked at proper intervals.
3	Functions for securing safety of Category 2 are duplicated.
4	1. Single faults shall be detected without fail. 2. Safety functions shall not be impaired by accumulation of faults. 3. Safety functions shall be duplicated by diversification.

4. Contents of measures taken to secure safety of AC servo press (SIT III safety control)

(1) Redundancy design of means of sensing slide position and constant monitoring mechanism

With AC servo press H1F, if the mechanism for sensing the slide position fails to sense the actual slide position due to a broken wire, some fault, disturbance, etc., it can cause a serious accident. As an extreme example, it can happen that the controller mistakes the top dead center of the slide (i.e., the top end of slide vertical motion) for the bottom dead center (i.e., the bottom end of slide vertical motion) and, as a result, the slide that is rising falls to the bottom dead center while the operator's hands are under the slide, causing severe injuries to the hands.

In most cases, a machine overrun (this term is often used of robots) is ascribable to the position sensing by a servomotor pulse coder alone or to the absence of a multiple position sensing system.

In designing a press, it is absolutely necessary to provide measures to positively prevent accidents due to an error in position sensing. For H1F, a triple slide position sensing system consisting of the following three elements, A, B, and C, is employed (see Fig. 4: H1F control system configuration).

- A. Position sensor that senses the absolute position of the slide
- B. Angle sensor that senses the absolute angle of the main gear which drives the slide
- C. Pulse coder of the servomotor which is the source of energy for slide operation

The above three position sensors are incorporated in SIT III. In addition, the deviation of each of the position sensors is constantly monitored at a preset level so as to prevent accidents which can arise from a failure of any of the position sensors.

Furthermore, the control that performs the position sensing and monitoring is composed of the elements of safety control described below.

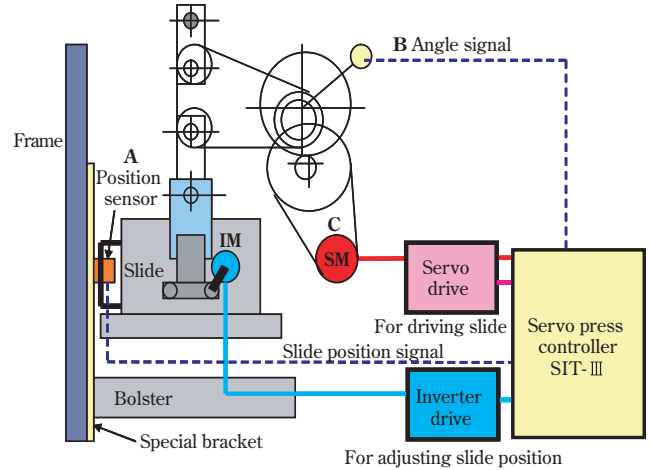

Fig. 4 H1F control system configuration

(2) Duplicated control circuit system and monitoring mechanism

Fig. 5 shows the control system configuration of SIT III as the means of safety control after input of an external signal. Since controlling the servo requires arithmetic operation, a

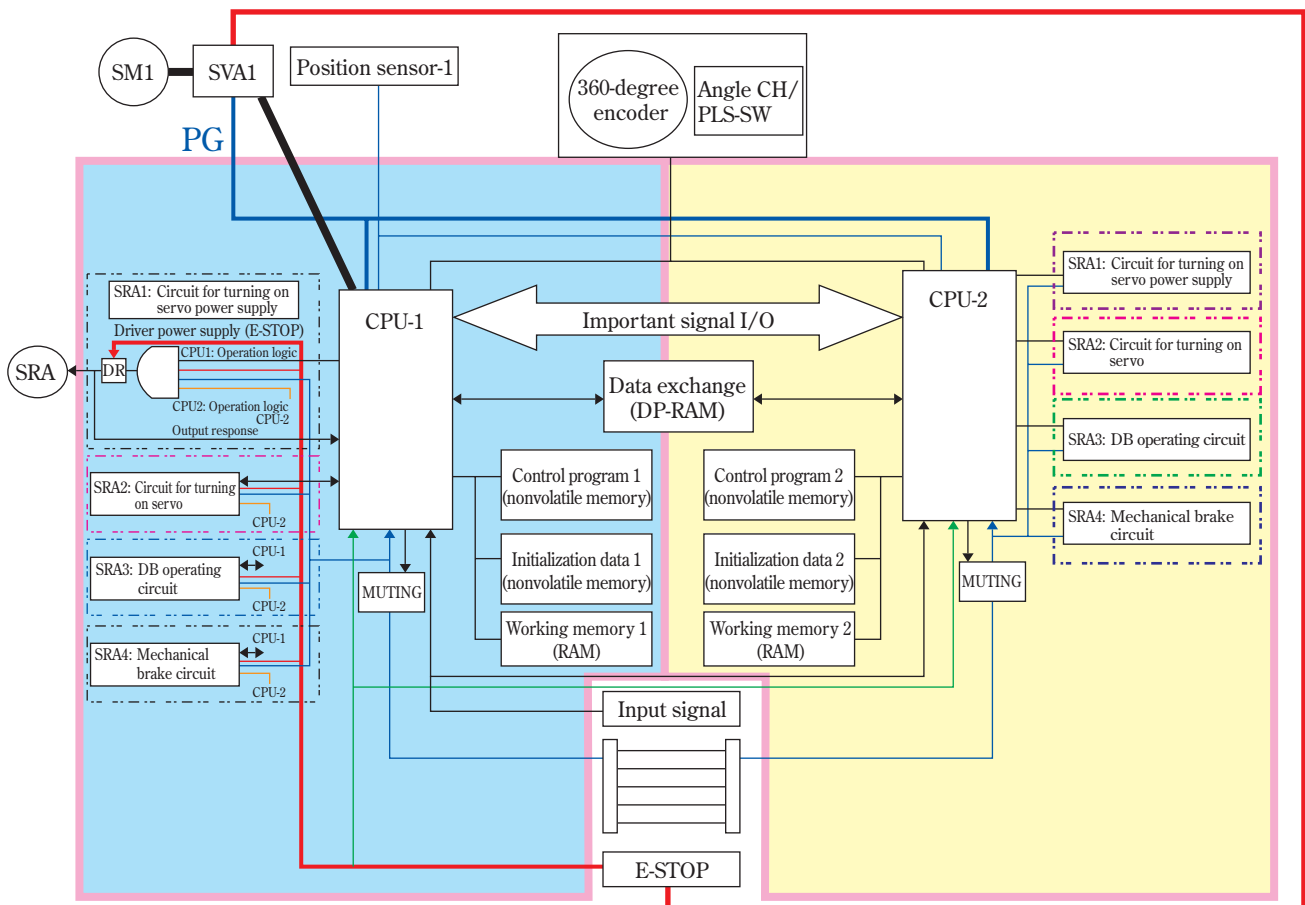

Fig. 5 SIT III control system configuration

microprocessor (CPU) is employed for the purpose. The basic policy on CPU-based safety control is as follows.

<Basic policy on CPU control>

- ① As a rule, all I/O operations are controlled by dual CPUs, which are of different type forming a dual circuit. (Table 3)

Table 3 External I/O configuration required for redundancy design of servo press (Pulse coder/linear scale processing is performed separately.)

No.	Input signal name	Output signal name
1	Emergency stop	Emergency stop output
2	Brake output feedback	Brake output 1
3	Servo power on feedback	Brake output 2
4	Off mode	Servo power supply ON 1
5	Inching mode	Servo power supply ON 2
6	Safety-stroke mode	Servo ON
7	Option mode	Safety device check
8	Continuous mode	
9	Preparatory inching mode	
10	Top dead center reset mode	
11	Continuous setup	
12	Emergency stop reset	
13	Operation button NO	
14	Operation button NC	
15	Front safety device actuation	
16	Rear safety device actuation	

- ② Each of the CPUs is provided with a memory for storing set values, etc. relating to safety control (duplication of memory).
- ③ Concerning the following mutual verification signals that are important for safety control, their control statuses are mutually monitored as important signal I/O. (Table 4)

Table 4 Duplicated internal processing of SIT III and mutual verification signals (important signals)

No.	Signal/processing system	Mutual verification signal		Output/control processing
		CPU-A	CPU-B	
1	Operation start processing	○	○	AND
2	Operation stop processing	○	○	OR
3	Positioning processing	○	○	
4	Emergency stop processing	○	○	OR
5	Stroke start judgment processing	○	○	AND
6	Stroke end judgment processing	○	○	AND
7	Positioning completion processing	○	○	AND
8	Halt judgment processing	○	○	OR
9	Servo linear scale anomaly processing	○	○	OR
10	Encoder anomaly processing	○	○	OR
11	Pulse coder anomaly processing	○	○	OR
12	Encoder program anomaly processing	○	○	OR
13	Linear program anomaly processing	○	○	OR
14	Safety device beam interception processing	○	○	OR
15	Safety device rise prohibition processing	○	○	AND



	CPU-A	CPU-B
Operation ready status	RDY-A	RDY-A
Automatic operation status	AUTO-A	AUTO-A
Servo on status	VON-A	VON-A
Front safety device status/rise disabled status	FCYCL-A	FCYCL-A
Rear safety device status/rise disabled status	RCYCL-A	RCYCL-A
Restart disabled status	ANTI-A	ANTI-A
Emergency stop status	QST-A	QST-A
Operation stroke confirmation	Stroke number-A	Stroke number-A
Positioning status confirmation	Positioning under way-A	Positioning under way-A

- ④ The control statuses of the other signals are mutually checked for their coincidence at all times.
- ⑤ The emergency stop circuit configuration is such that the output is cut off by hardware when the input is interrupted.

- ⑥ As for important output signals, such as the brake output signal, the conditions of output and feedback are constantly monitored.

Thanks to the basic design of CPU control mentioned above, even if any single failure occurs, the system positively detects and identifies it to prevent it from leading to a serious accident.

(3) Duplicated starter circuit and monitoring mechanism

As shown in Fig. 1, the press starter circuit is actuated by two-hand operation switches. The start/end of press operation is judged by the NO (normally open) and NC (normally closed) contacts of each of the right-hand and left-hand switches, and the press operation is controlled by dual CPUs.

In the conventional starter circuit control, the right-hand and left-hand operation switches are controlled by series-connected signals input to each of two CPUs (dual CPUs) as shown in Fig. 6. Namely, although the press operation is performed by both hands, the starter circuit is controlled by the NO and NC circuits provided with a 0.5-second interlock for switching between them. This method of control has not been questioned by any of domestic and foreign safety standards (JIS B 9960-1 (IEC 60204-1): Two-Hand Starter Type III).

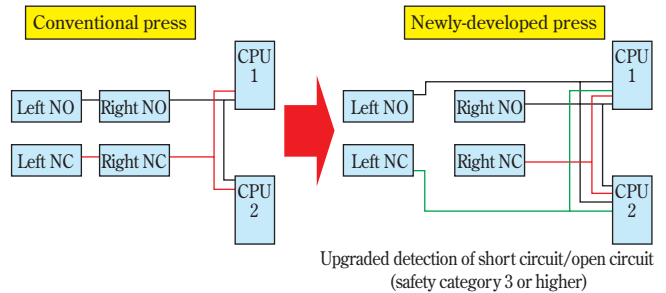

Fig. 6 Duplicated starter circuit and monitoring mechanism

In recent years, a new interpretation of press-related standards is calling for a high degree of safety of hand-in-die type presses. As a result, safety units for two-hand operation have been put on the market, and the prevention of a restart in the event of any single failure of either the right-hand or left-hand operation switch is guaranteed.

The most dangerous operation of a hand-in-die type press is starting the press by a single hand. In this respect, in a risk assessment, it is necessary to consider eliminating the possibility of single-hand operation due to some trouble with either of the operation switches.

In studying the safely control of AC servo press H1F, on the basis of a risk assessment, we made arrangements to detect every single failure of the starter circuit and further improve the safety of control to prevent accidental restarts. In addition, in order to attain as high a level of safety as possible in the future, the following two control elements (② and ③) were provided.

- ① A 0.5-second interlock for the switching between “NO” and “NC” in operation of two-hand operation switches (conventional control)
- ② A 0.5-second interlock for the switching between “NO” and “NC” of each of the right-hand and left-hand operation switches
- ③ Detection of simultaneous ON or OFF of “NO” and “NC” of each of the right-hand and left-hand operation switches

(4) Overrun detection and redundancy design of circuit breaking

① Overrun detection function

The most dangerous thing in the operation of the H1F AC servo press is this. In one safety stroke, the operator assumes that the press will stop at the top dead center, and inserts his hands into the dies to take out the finished product while the press is ascending. In this case, if the press overruns and the slide comes down, it can cause a serious accident.

With the H1F AC servo press, if its servomotor overruns, it is not always possible to prevent a serious accident by the conventional overrun detection (i.e., detection of the slide overrunning the top dead center) alone. Needless to say, detection of an abnormal deviation (i.e., detection of a deviation of the amount of movement from the command at a preset level), which is a common function in servo control, is also implemented. However, this is also insufficient to prevent a serious accident because the level of response of detection is limited.

In order to solve the above problem, the H1F AC servo press is provided with the following functions to positively detect an overrun.

<1> Function of monitoring press deceleration status

As mentioned above, if the servomotor of the H1F AC servo press overruns, it is not always possible to prevent a serious accident by the conventional overrun detection alone. In order to solve this problem, H1F is provided with a mechanism which monitors the deceleration condition of the press till the slide stops at the top dead center in one safety stroke and minimizes the amount of slide overrun by stopping the slide as required.

Fig. 7 shows the outline of detection of an abnormal servo deceleration/stoppage in the process of deceleration in the control for stopping the press at the top dead center. With H1F, in addition to the detection of a slide overrun, as soon as the control of press stop at the top dead center is started, detection of any servo overrun before the slide begins descending is started by constantly monitoring the servo deceleration control condition taking into account the delay in response to the deceleration command (T1), etc. If a servo overrun is detected, the press is emergency-stopped by first turning off the power supply and then applying the mechanical brake.

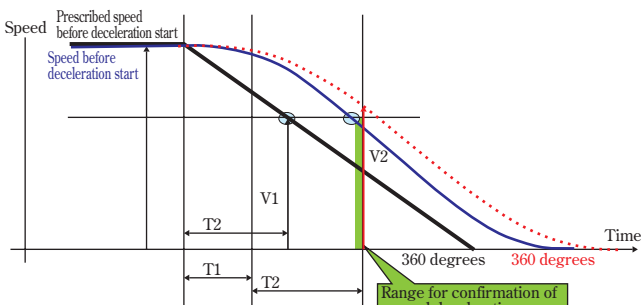

Fig. 7 Detection of abnormal servo deceleration operation
 T1 (delay in response to deceleration command)
 T2 (detection start time after start of deceleration)
 V1: Calculated speed of speed detection
 V2: Actual speed of speed detection
 After start of the deceleration command during stop at the top dead center (one safety stroke, continuous, one stroke, or other option), the function monitors V1 and V2 after the time (T1 + T2) and, if V2 > V1, the function detects it as a brake trouble.

Fig. 7 Detection of abnormal servo deceleration operation

<2> Function of detecting excessive amount of shift of servomotor

With H1F, the command to shift the servomotor is given as a specific amount of pulse from SIT III to the servo-amplifier, which then inputs the pulse to SIT III as a feedback of the amount of shift of the servomotor. By checking if the feedback value is greater than that of the command, SIT III can detect an overrun of the servomotor as early as possible. This is very effective to detect an unexpected servomotor operation when no command has been given. Namely, if an overrun of the servomotor causes an unexpected start of the press, this function is capable of stopping the press before the servomotor reaches a dangerous speed.

② Redundancy design of circuit breaking

Even when the functions of detecting an overrun, etc. are working properly, it is extremely important to secure safety by ensuring sufficient reliability of the energy cut-off and break circuits for stopping the press.

Fig. 8 shows the SIT III control blocks relating to circuit breaking.

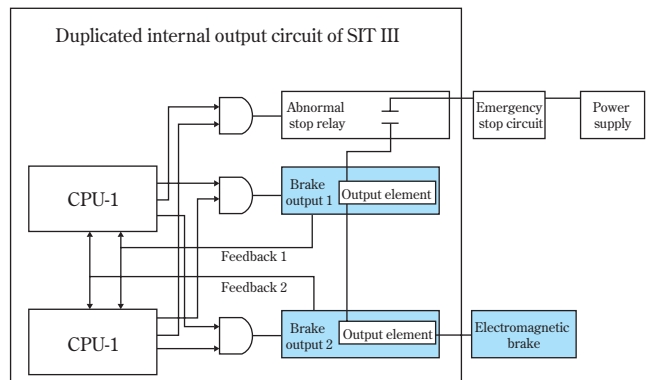

Fig. 8 Redundant circuit for circuit breaking (prevention of release of brake)

The circuit is so constructed that only when brake output 1 and brake output 2 turn on simultaneously, the press brake is released, enabling the press to be operated. If some abnormal condition occurs, both brake output 1 and brake output 2 turn off, preventing the electromagnetic brake from being excited.

The output elements incorporating brake output 1 and brake output 2 are in an AND relationship with the output of CPU 1 and CPU 2, and a feedback signal for detecting a failure of either output element is input to both CPU1 and CPU 2. Thus, a failure of each element is detected by checking its output condition by means of the signal it feeds back to the CPUs.

In addition, SIT III is provided with a relay circuit which is higher in order than brake output 1/brake output 2 and which cuts off the power supply line when some abnormal condition occurs. This helps improve the reliability of the duplicated output elements.

The external circuit that consists of an emergency stop switch, etc. is so constructed as to directly cut off the press driving circuit in an emergency.

5. Conclusion

We have so far described the safety control of the newly-developed H1F AC servo press of hand-in die type.

Despite the fact that the AC servo press is one type of press, it has such a unique structure (not having a clutch brake) that it does not fall into the category of a press from the standpoint of applicable standards. In developing the safety control of the new press, therefore, we referred to the existing domestic structural standards for power mechanical presses, the safety guides for presses, and the draft of the next structural standards where appropriate. In addition, we carried out a risk assessment to determine suitable control mechanisms. Furthermore, we took a trial-and-error approach to come up with every possible method for securing the safety of the AC servo press.

If standards and regulations for AC servo presses are established and International Product Safety Standard (C) is made applicable to them in the near future, it will become possible to obtain international recognition of AC servo presses. In the future, we intend to strive to improve and spread the safety control of AC servo presses while paying careful attention to the development of relevant standards.

Introduction of the writers



Yukio Hata

Entered in Komatsu in 1983. Currently working in Forge Press KBU, Komatsu Industries Corp.



Hitoshi Sakurai

Entered in Komatsu in 1985. Currently working in Forge Press KBU, Komatsu Industries Corp.



Hisanori Takeuchi

Entered in Komatsu in 2001. Currently working in Forge Press KBU, Komatsu Industries Corp.



Yoshinori Matsushita

Entered in Komatsu in 2002. Currently working in Forge Press KBU, Komatsu Industries Corp.

[A few Words from the writers]

To Komatsu, nothing is more important than ensuring the safety of the customer. With the belief that “press control consists in safety control,” we intend to make continuing efforts to develop safer and more reliable machines.